

Alden

Grabit®

Damaged Screw Remover



POWER DRIVEN

Easy to use with a 3/8-in. variable speed reversible drill



WARNING

Always wear safety glasses & protective clothing when operating or near power tools.

1. Screw remover for to be used in a variable speed hand drill set for reverse.
2. Can be used in "quick Change" type chucks for fast, efficient usage. Remover can be used with most screw types such as Hex, Phillips, Torx, Square Drive, etc. Can work on wood, sheet metal, mechanical and other screws.
3. Tool can be compromised if extracting large screws exceeding 2 inches in length and/or have aggressive threads.

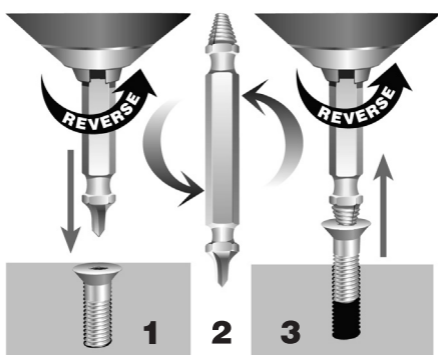

OPERATING INSTRUCTIONS

1. Burnishing

- a. Be certain the work piece is secure and will not move during the use of this remover.
- b. Insert remover directly into drill or quick-change chuck so burnishing end is showing.
- c. Set drill for reverse (counterclockwise)
- d. Place burnishing end of tool into the center of the damaged screw, and apply power to your hand drill while applying pressure towards the screw. Stop when there is a distinct 1/16" deep clean area in the center of the screw head.

2. Remove burnishing end from chuck, flip tool, replace into drill chuck with Remover end now showing.

3. Removing

- a. Maintain reverse setting (counterclockwise)
- b. Place remover end of tool into now smooth screw head.
- c. Apply firm downward pressure, drill at slow speed. Apply lowest level of power to the hand drill.
- d. Remover end of the tool will thread into screw head and remove. For free spinning screws, pull drill lightly away from the threads holding the screw.

Reusable

This damaged screw remover is reusable. Clean chips off tool and lubricate with oil after use.

Helpful Hints

For hard to remove screws, and if the remover slips or does not bite into the screw, re-burnish the screw so that the contact area is an additional 1/16" deeper than before. Or, if applicable, try moving up in remover size repeating each step from the beginning of these instructions. Caution, both of these helpful hints could compromise the screw head or the tool.

Screws

Grabit # 1	No. 4 - No. 7
Grabit # 2	No. 8 - No. 10
Grabit # 3	No. 11 - No. 14
Grabit # 4	No. 16 - No. 24

www.aldn.com

Alden

Patented: USA #6,761,089; 5,251,516; D-340,184.

Canada #2,490,546. Made in China.

Grabit® is a registered trademark of Alden Corp.